



Porcelain Firing Furnace
VACUUM PORCELAIN FURNACE

AT-300



Contents

Contents	1
Dear Customer	3
Taking out the Furnace from the Box	6
Content of the Box	7
Components of the Machine	8
Connections of the Machine	9
Technical Specifications	10
Basic Information	11
Installation and operation	12
Security of Installation	13
Environmental	13
Front Panels, keys and their abilities	16
Lift Control	16
Temperature Change	16
Lamp key	16
Enter key	16
Clear key	16
High/Low key	16
Help key	16
Change and operation of firing program adjustment	17
Default firing program	17
Firing Program adjustment	18
Program parameter introduction	18
Low Temperature	18
Drying Time	18
Door Lift Setting	19
Powder firing Temperature	19
Speed of Temperature raise	19
Hold time powder in firing Temperature	20
Cooling Temperature furnace	20
Measure and duration of prevacuum	20
Measure of Main Vacuum	20
Time of Vacuum Initiation	21
Evacuation Temperature/ Evacuation Time	21
Program Change	22

Peripheral Programs	22
IDLE Programs	22
Night Program	23
Dry Program	23
Adjustments	26
Clock Set	26
Calibration	26
Help Language	26
Machine Information	27
Vacuum Calibration	27
Fast Cooling	27
Troubleshooting	30
Life-extend ending	32
Connecting us	33

Dear Customer

With thanking your choice, This Furnace you bought is an efficient tool produced by lots of experience of heating in vacuum on porcelain and various alloys, benefiting most up-to-date world technology which guarantees the quality of your work for years.

You will be able to work with different materials of any company and gain your expectations from your advanced porcelain furnace.

Temperature control with plus/minus error of 1 degree (33.8° Fahrenheit) by modern controllers are provided in this new machine for the operator.

Please read this manual before use carefully.

This manual is an important reference for good use & safe of this machine which considering of important information on the correct use of the machine with highest standard. Noting this information may help you prevent the probable hazards. Also it may help you reduce the costs, energy and extends machine useful life time.

All the images and illustrations and descriptions in this manual are for the operation of the machine and does not include structural information.

We hope that you will find using AT300 to be an enjoyable and successful experience

Polaris Engineering and Manufacturing

POLARIS AT-300

Specifications (Features)

Taking out the Furnace from the Box

Packing of your furnace is prepared with suitable design for physical safety and conforming the related standard. This package is waterproof and mechanical shock in the span of related standards.

For taking out the furnace and its peripherals first you should put the package in correct position; so that the signs ↑...↑ be in the up-right position, then open the upper door & soft protection parts should be taken out, then take out the machine itself in a suitable place.

Note: For ease and future safe movement, try to keep safe the box and other related joints matters.

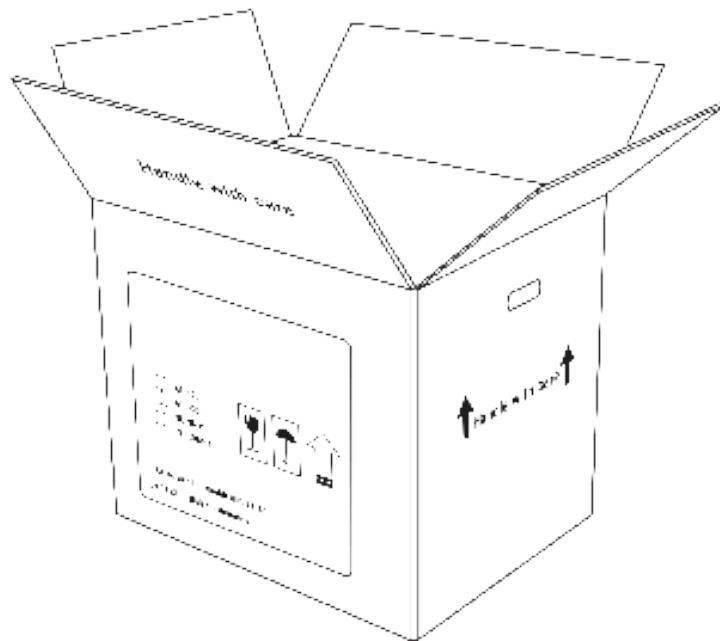

The Contents of Polaris Furnace Box

AT-300 Furnace

1. Manual
2. Vacuum pump
3. Pin and ceramic base
4. Work base
5. Vacuum Hose
6. Electric Cable

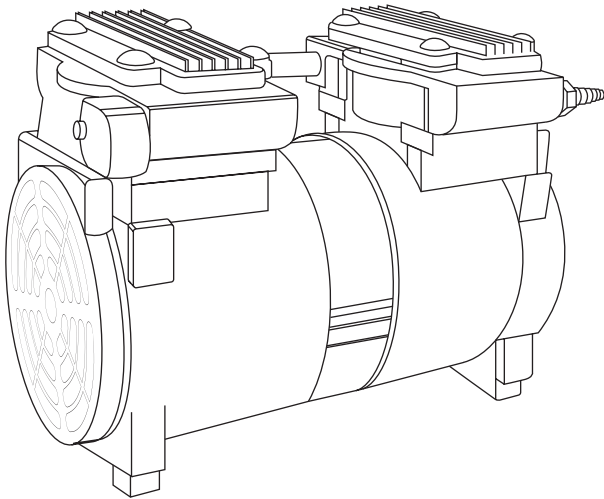

Vacuum pump

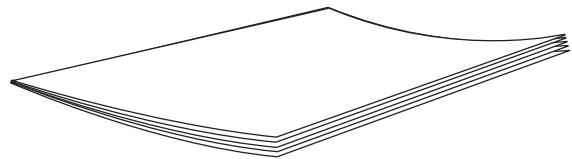

Manual

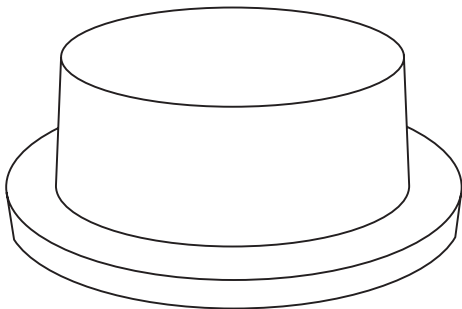

Work base

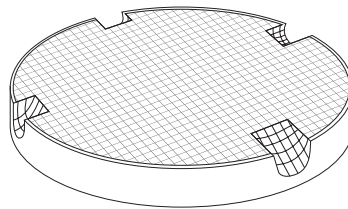

Pin and ceramic base

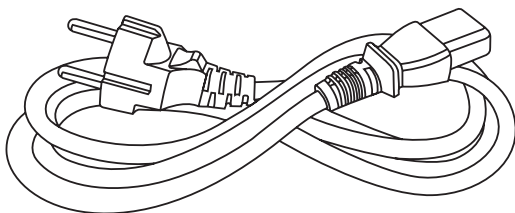

Electric Cable

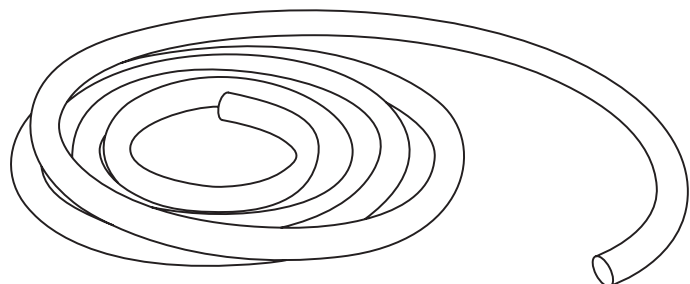

Vacuum Hose

Apparatus Specifications

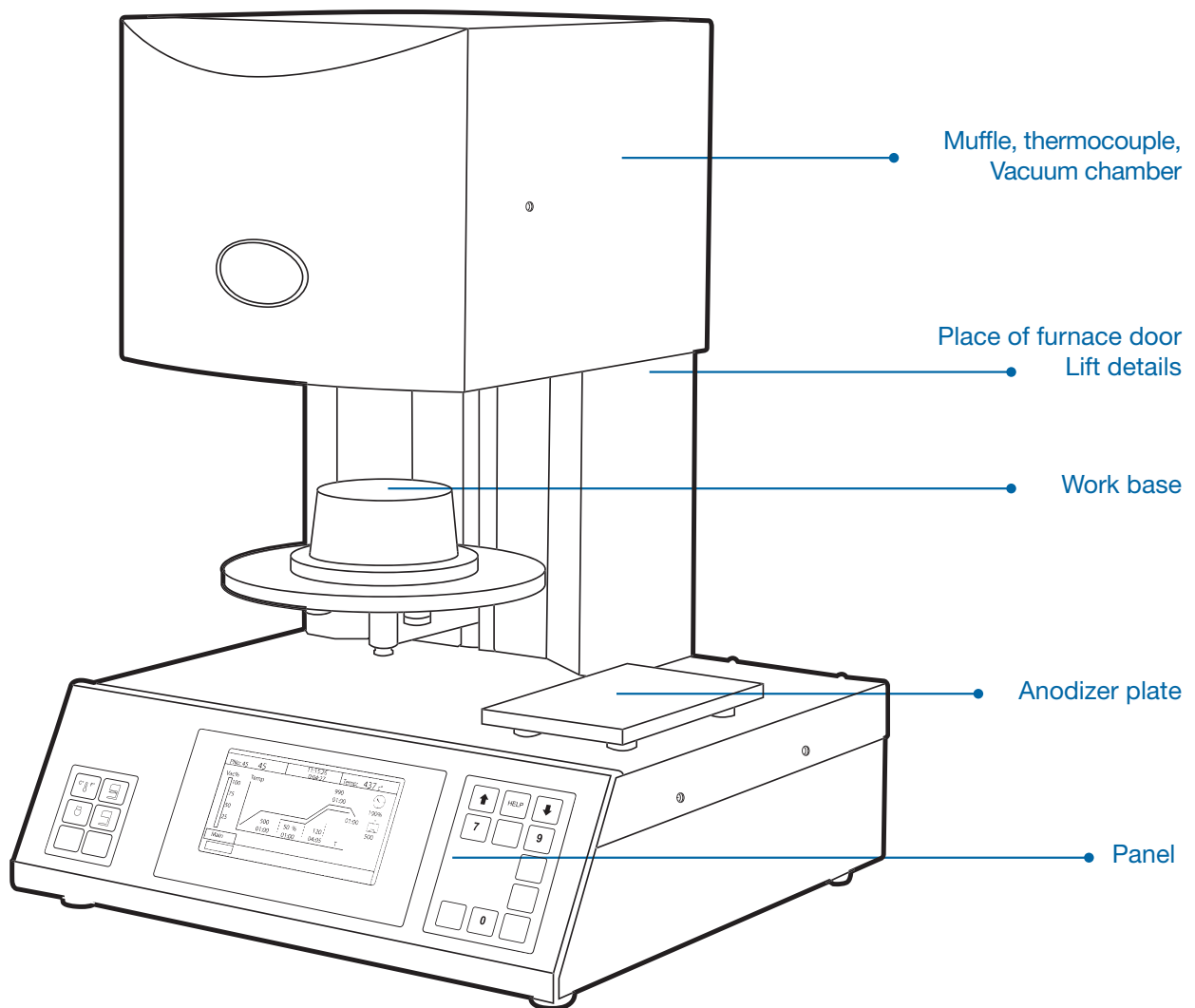

Apparatus Connections

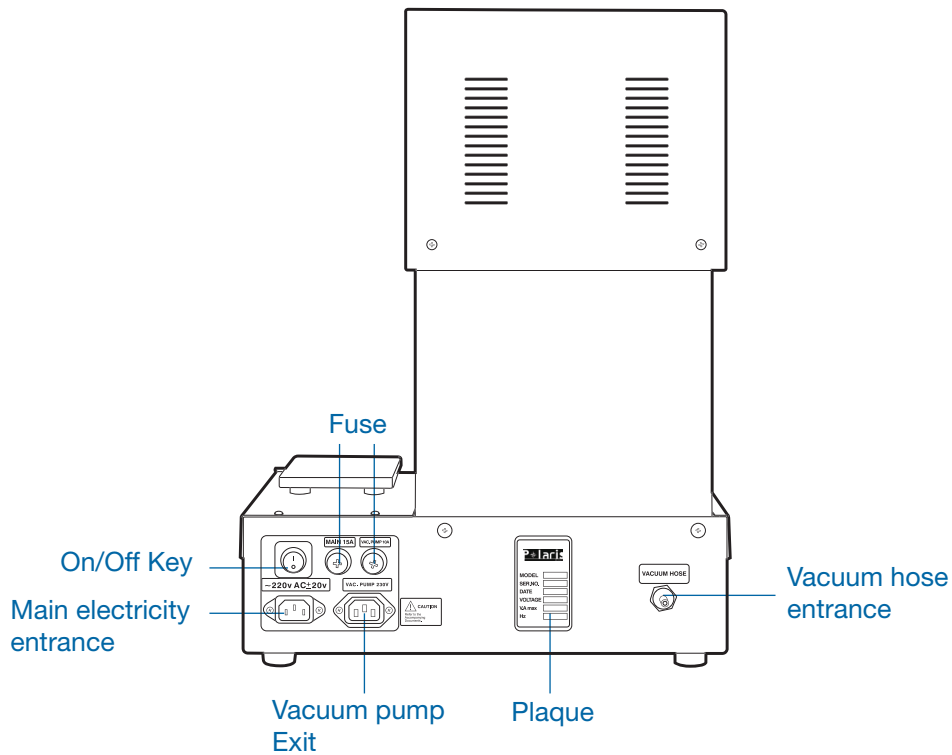

Fuses

On the rear side of the furnace two fuses are placed which are related to the main electricity of the apparatus; while the measure of each one is imprinted on it. In case of event of problem replace the fuse with a new one. (Images No.1-3)

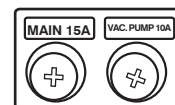

Technical Specifications

Dimensions and weights of Furnace:	Width : 390 mm.
	Depth: 365 mm.
	Height: 530 mm.
	Weight: 21.5 Kg.
Practical measures (firing chamber):	Diameter: 90 mm.
	Height: 55 mm.
firing chamber	Maximum centigrade: 1200° (Fahrenheit 2192°)
Wattage of Apparatus	
Electrical feeding of Apparatus:	220 V., AC, 50Hz
Apparatus Electrical consumption:	Maximum 1800 w.
Vacuum pump	
Wattage:	220 v. Ac, 50 Hz
Wattage:	250 w.
Maximum vacuum pressure:	740 mm. Hg
	Dimension's: 320 X 110X 220 mm.
	Weight: 6.5 Kg.

Furnace General Information:

- Modern technology and best temperature controller with extraordinary precision for optimum results to the operators of AT-300 Furnace.
- Reduction time of operation, employing modern technology in construction.
- Complete Display of phases.
- Firing compartment isolated by high quality material.
- Spiral Quartz Tube
- Heat sensor (platinum / Radium – Platinum)
- Firing precision Temperature + 1°centigrade (33.8 °Fahrenheit)
- Suitable vacuum pressure and ability of its control in all phases.
- Automatic temperature calibration.
- Vacuum calibration in software mode.
- Temperature calibration automatically
- Vacuum calibration in software mode

Primary information on the structure of the apparatus

The apparatus was built based on the engineering methods and all safety principles were considered. Nevertheless, in case the apparatus is operated in non-standard form, it may result in unpredictable injuries. Also incorrect use of apparatus may lead to damaging and malfunctioning.

Incorrect use

Using tools, machines and apparatus etc. which are dangerous or have hazardous effect on the operator are not recommended. Also all apparatuses which have been manipulated by operator cannot be used.

The correct use procedure

Using this apparatus is only authorized for those who have read this instruction manual and perceived the correct use of the apparatus completely. Incorrect use may lead to insufficient performance and lack of efficiency, so the provider has no responsibility on the abuse of the apparatus. The user is responsible for the risk of incorrect use.

Installation and Operation

- 1 Take out the apparatus from the package with care. For this, put out the Plastophomes, then take out the furnace, and put it on a level surface, standard laboratory table, so that a 25 cm around the apparatus would be free and clearance of anything. Note that the area of the table and its legs are not of metal material. Important Note: if the table or its legs are made of metal and they are in contact with earth, there would be hazard of electrification. So, put your furnace on wood or fiberglass table.

Note: Keep the apparatus in a dry-warm place.



- 2 In case the temperature is lower than 15° (centigrade 59° Fahrenheit) (for example, after displacement) let at least 30 minutes in order to reach to the equal level of furnace and room temperature.



- 3 Ensure that the plate on which the apparatus is placed, is resistible against heat. Areas and some surfaces which are sensitive to heat may lose their color.



- 4 The Earth wire of the apparatus should be connected to the earth of city electricity. In case that there is no Earth pit, connect the wire to the nearest radiator or water pipe if they are of the metal texture.



- 5 Do not expose the apparatus to the direct sunshine.



- 6 Do not place the inflammable material close to the apparatus.





- 7 Do not place anything on the firing chamber while working.



- 8 Install the apparatus in an appropriate place in order not to face any problem turning on and off.

Safety tips

Safety labels on the furnace

 <p>Danger electric shock risk</p>	This label warns electric shock	Hazard us Voltage
	This label means using 220 Vac with 10% tolerance	alternative electricity 220 v.
	This label means that the Earth wire of the apparatus should be connected	Earth
	This label means that the surface will be heated between 25° to 450° centigrade	Hot surface
	This label means the lift can damage the objects which are in its path	Movable surface

Environmental condition

- The device is designed for indoor use
- The optimum temperature: 15°- 40° centigrade (59° Fahrenheit - 104° Fahrenheit).
- The optimum moisture: less than 80 % in a temperature of 31° centigrade.
- Voltage: should not exceed $\pm 10\%$ of the defined voltage.

POLARIS AT-300

**Introduce Panels, Switches
and their abilities**

Introducing front Panels, Keys and their Abilities

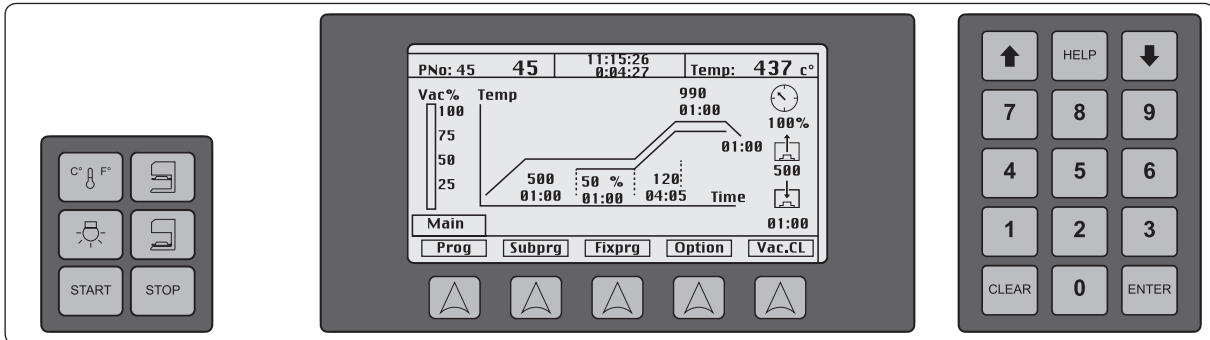

Lift control:

The above keys were designed to control the lift. The up key is used for lifting and the down key is used for shutting the door of machine.



Changes in the scale of temperature is based on Fahrenheit or Centigrade:

The above key is used for changing the scale of temperature according to Fahrenheit or Centigrade.



Lamp key:

The above key is used for turning off/on the lamp located on the beneath of the higher frame of the machine.



Enter Key:

This key is used for registering the changes in all programs and furnace settings



Clear key:

This key is used for deleting the changes in all programs and settings of the furnace.



Up and down keys:

Up and down keys are used for moving through switches displayed on the screen board.



Help Key:

The help key is designed in each section for necessary guides. For using this key, you should enter each section and then push the Help key. Thus you can gain a brief explanation about the section. For choosing the language of help refer to page 26.)

Setting, changing and operating the firing program (ceramic furnace program)

Number of programs and the memory of AT-300 Furnac

This furnace has 300 memories. For your convenience and easy access to firing tables of powders and various alloys of different brands, programs 100~300 have been gathered and registered from manufacturing firms as defaults preserved in the memory of your apparatus; while the programs numbers 0 ~ 90 are empty and considered for your favorite programs and you can make your plans and changes there. The default firing programs are defined as a series of ready-made packages which are provided by the company and will be given on the customers. **Image No.1**

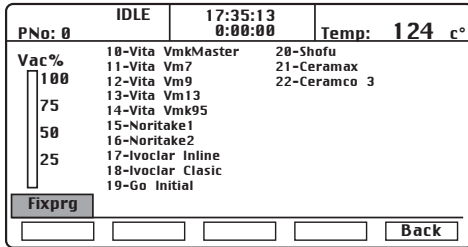

Image No.1

A ready package includes 13 following parts which consists of programs number 100~300:

- 10** Vita powder VMk Master
- 11** Vita Powder VM13
- 12** Vita Powder VM 9
- 13** Vita Powder VM 13
- 14** Vita Powder VMk 95
- 15** Noritake Powder(1st package)
- 16** Noritake Powder (2nd Package)
- 17** Ivoclar Inline
- 18** Ivoclar classic
- 19** GC initial Powder
- 20** Shofu Powder
- 21** Ceramax Powder
- 22** Ceramco powder

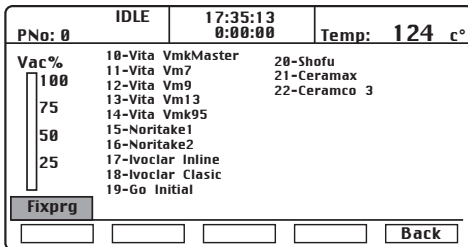

Image No.2

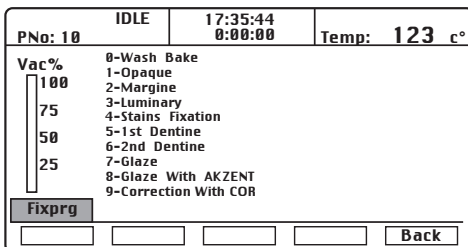

Image No.3

By using each the above packages you can see all of the phases related to the firing powder and for this process, you just need to enter the relevant number and push Enter. For example for the first round firing powder vita VMK Master, for choosing the powder package of VMK Master, you initially enter No. 10. Then enter the number 5 for firing powder. In this step number 105 will be displayed which means program 105 related to 1st cooking of VMK Master powder, then push "Enter" key; for the program to be loaded. **Image No. 3**

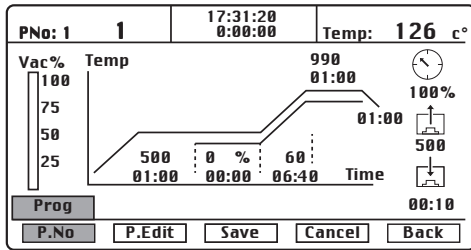

Image No.4

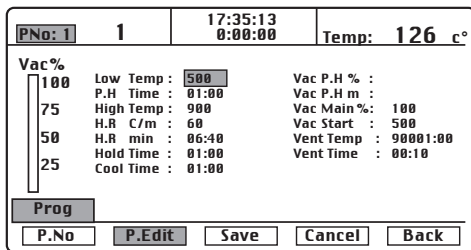

Image No.5

Setting of the firing program

For setting your favorite firing program, you can choose program NO. 0-99 and set the ideal position. For this purpose follow these steps:

Note: Dear operator, before setting any furnace program; please consider the porcelain type and the used alloy; study the catalogue, instruction and thermal table of manufacturing company for setting the furnace.

In some cases the suggested program of manufacturing company needs some slight amendments and changes for attaining the suitable quality.

- Push the PROG key, then "P.No" Key **Image No.4**
- Now, by using keys, choose your own program.
- Push Enter key to enter the desired program by this you can apply your own changes **Image No.4**
- Push "Edit" Key Program and enter the setting section. **Image No.5**

Program parameters Introduction:

Low Temp

Drying temperature (Low Temp):

Low temp or drying temperature refers to the initial temperature for the time of porcelain drying.

Low Temp Entrance range:

Temperature: around 200°~800° centigrade

You can confirm the set information by "Enter" Key and choose the former amount of program by up and down keys.

P.H Time

Drying time:

Drying time or pre-heat time means the amount of time the powder remains in drying temperature or Low Temp. In this time the door of furnace will be closed.

The entrance range:

Time: 0 -100 minutes

You can confirm the set information by "Enter" key

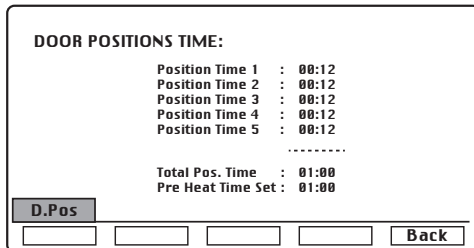

Image No.6

and choose the former amount of program by up and down keys.

Adjustment of rising door

This part of the program which is the new facilities in this apparatus is used for raising the quality of firing. In this part you can adjust your furnace door in a best possible position so that the best function will be obtained.

The furnace door of AT-300 is closed in 5 phases. The time for each of these phases in default position will be divided equally. For example if the time of drying is 1 minute, the machine automatically sets 12 seconds for each part. In case, the operator wants to apply any changes to the manner of lifting; after determining the drying time that is P.H Time; you should push the "Enter" Key and enter the phase of door's placement settings. **Image No.6** In this phase, you can set ideally each sections from 1 to 4. It is needed to mention that 5th section will be adjusted automatically based on the remaining time.

High Temp

Powder firing Temperature

The High Temp is the maximum temperature in every thermal cycle.

Data entry range:

Amount of temperature: Maximum 1200°

You can confirm the set information with "Enter" Key and choose the former amount of program by up and down keys.

H.R C/m
H.R min

speed of raising the Temperature (Heat Rate Min and Heat Rate C/M)

These parameters are the speed of the temperature rising from Low temperature to firing temperature (High Temp) and acts with two units, the first kind which is based on the temperature upon minute and 2nd kind of temperature which is based on the time Through the distance and is of the quality of time.

Data Entrance range:

Amount of temperature upon minute:

20°-120°Centigrade.

Amount of time: The given amount should be in a way that the calculated Heat rate becomes between 20°-120°.

You can confirm the set information by “Enter” key and choose the former amount of program by up and down keys.

Hold Time

Hold time in High temperature

This parameter is the time that the furnace is kept in the High Temp.

Data entrance range:

Amount of time: 0 minute to 100 minutes.

You can confirm the set information by “Enter” key and choose the former amount of program by up and down keys.

Cool Time

Temperature of furnace cooling (cool time)- the time of door opening

It means that the door takes time to get opened and the work is ready to be delivered.

Data entrance Range:

Amount of time: 10-100 minutes

You can confirm the set information by “Enter” key and choose the former amount of program by up and down keys.

Vac P.H % Vac P.H m

Time and amount of pre-vacuum (Vac P.H m and P.H %)

Pre-vacuum is the operation which is applied before the main vacuum. These operations which have been created in the new generation of furnaces, give you the opportunity to use vacuum when the temperature is fixed and in its initial amount.

Data entrance range:

Vacuum amount: 0%-100%

Time of Vacuum: 0-100 minutes

You can confirm the set information by “Enter” key and choose the former amount of program by up and down keys.

Vac Main

Amount of the main Vacuum (Vac Main)

This amount refers to the vacuum level which is needed to complete the firing. This amount of vacuum will be applied from the moment that the apparatus' door is

locked and in the period that temperature reaches from low temperature to vent temperature which will be performed in the chamber of furnace .

Note: It is recommended that the vacuum level should be kept to the maximum rate that is 100%.

Entrance range:

Vacuum range: 0%-100

You can confirm the set information by "Enter" key and choose the former amount of program by up and down keys.

Vac Start

Main vacuum initiation temperature (Vac Start)

The temperature in which the apparatus starts to vacuum.

Entrance range: Low Temp \leq Vac Start $<$ High Temp

You can confirm the set information by "Enter" key and choose the former amount of program by up and down keys.

Vent Temp Vent Time

Vent Temp or Vent Time

This is the amount of temp or time in which the vacuum of apparatus is evacuated. Evacuating the vacuum, or in the other word, the inlet air to the thermal chamber can be done in two status:

① Vent Temp:

The evacuating of vacuum is based on the temp and you can deplete vacuum in equal temp or a temp lower than high temp. For example if the high temp is 940° centigrade, the vent Temp can be 940° or lower. The setting of this temp may be depended on the experiences of the operator or the kind of material used.

② Vent Time:

The evacuating of vacuum in duration of the Hold Time can be programmed.

In the other words, the vacuum evacuation according to the time is done on the Hold Time phase. Furnace has reached to the heat of High Temp and Hold Time getting started. Now you are able to control the vacuum in Hold Time. The level of vacuum may be retained in Hold Time or lower than that.

Therefore, you can control the initiation of creating vacuum and vacuum evacuation at all stages of the thermal cycle based on your need, experience and thermal cycle of used material.

Entrance range:

Vent Temp: Vent Temp \leq High Temp

Vent Time: Vent Time \leq Hold Time

You can confirm the set information by “ Enter” key and choose the former amount of program by up and down keys.

After completing the setting of the furnace programs, now for preserving the adjustment of the program you should push the Save key.

Program Change

In any time, before initiating a program or during a program, the operator can change the parameters of the program if needed. All of the aforementioned factors could be changed and during the running of the program the factors which have not been applied yet are subject to be changed before the initiation of the program.

It should be mentioned that the changes rendered through the program are preserved only during implementing the program and after performing the program, these changes will turn back to the former numbers.

Peripheral Programs:

Idle program:

The word “Idle“ means rest time, it is better Not to turn off the furnace in rest time and use idle program. This operation leads to increasing the muffle life of the furnace and the speed of your action.

For programming and applying the idle program, do as follow:

■ Push the “Sub Prg” key and enter to peripheral program.

In this section; after the termination of each firing program; if performing the program is needed, * push the Idle Mode key and enter the automatic performance section.

■ If you need automatic performance, put the “Idle Mode” in the “Yes” mode and otherwise put it on the

“No” mode.

■ If Idle Mode is in the automatic mode, this program can be performed manually through “SubPrg” and then “IDLE” program.

■ For the setting of the IDLE temp, you should go to IDLE section and press the Prg Edit key. In this section you can only adjust the temp and the rate of vacuum.

Note: It should be mentioned that in automatic performance of IDLE program, the temp of the machine is fixed on the initial firing temp of the last firing.

Night program:

Night program is a fixed program which keeps the furnace temperature on 200° centigrade accompanied with vacuum.

This capability is used for long idleness of the machine in order to avoid moisture penetrating to the muffle and as a result useful life of the machine.

The phases of applying the program are as follow:

■ Put the furnace in ON mode

■ Press the “Sub Prog” key and enter into the peripheral programs.

■ Press the “Night” key and enter Night program.

■ Press the “start” key to perform the program automatically.

Note: This should be mentioned that the Night program has no changing Capability.

Drying Program (DRY):

Muffle of Auto Therm 300° furnace is designed and made with the least weight and best isolating material.

This material is resistant against moisture. In case you face with any leakage and to loss of vacuum after running and first working with furnace, perform “DRY” program. Leakage or losing vacuum happens after steaming the moisture on the door or within the muffle isolating material in 1000° Fahrenheit or higher which has turned into gas and cause lower rate of vacuum in the muffle box.

“DRY” program is a fixed and unchangeable thermal cycle which its digital amounts of 9 parameters are adjusted by the experience and no tool or teeth can enter into the muffle in this program.

POLARIS AT-300

Setting the Furnace

settings of furnace AT-300

By pressing the Option key, you can enter to the setting section.

Apparatus clock settings

After entering the setting section of the apparatus, by pressing “CLK set” key, you can enter the software setting of apparatus clock. **Image No.1-7**

In this section you can make the necessary settings of the clock as follows:

For setting hour, press the Hour key, then set the hour by up and down keys.

For setting minute, press the Minute key and set the minute by up and down keys.

For setting seconds, push the second key, set second by up and down keys and finally press the Save key; therefore, all your activities are preserved in the apparatus memory.

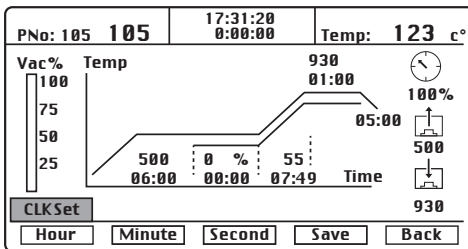

Image No.1-7

Apparatus calibration

The calibration section of apparatus ; which is shown by the abbreviation of "calib"; is for setting the furnace temperature. This section is the only calibrated part of machine accessible to the operator. **Image No.2-7**

By pushing key "U.cal", we enter the calibration part of the apparatus and can change the No. 960 by the digits which are located on the right side of the key board. For example, according to the experience and specifications of the former firing regarding the color and transparency of work, the operator concludes that the apparatus firing with a particular deviation is less than the optimum phase. For example, the operator diagnoses that the temp of furnace is 15 degrees low. In this situation, he should enter a number with 15 degrees less than the real one (i.e. 945) and presses the Save key.

Note: This apparatus does not need silver wire or peripheral tools for heat calibration (calibration kit) and practically the heat calibration has been done in the factory. This method is for better firing.

The apparatus Help language

For changing the Help language of apparatus, the operator can choose between Germany and English languages and use them. **Image No.3-7**

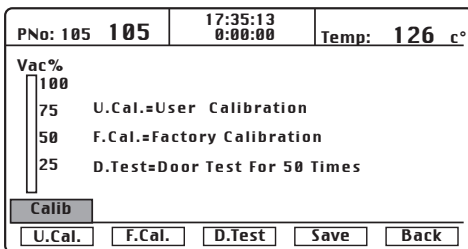

Image No.2-7

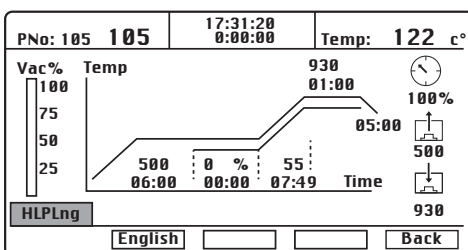

Image No.3-7

Apparatus information

In the settings and info. sections, you can see the following

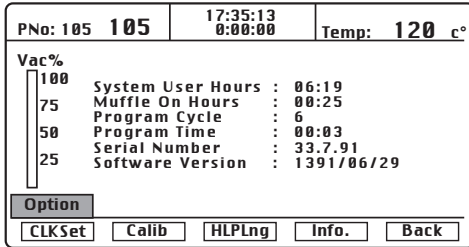

Image No.4-7

information about your machine. **Image No.4-7**

- The number of hours that your apparatus works
- The number of hours that the Muffle works
- The number of operated programs
- The time of the program operation
- Machine serial number.
- Software version

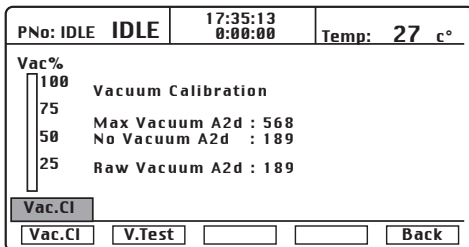

Image No.5-7

Calibrating the apparatus vacuum

Automatic setting of vacuum or vacuum calibration automatically is another new facility of AT-300 furnace which is used as follows:

After entering the calibrating vacuum section or VAC. CL you encounter with two menus of VAC. And V test.

Image No.5-7

You can check the apparatus vacuum by “Test“ key and if any deviation is observed you can calibrate it.

For testing the vacuum, first you should press the V.test and follow the number which is in front of the Raw Vacuum, this number should be fixed with a low deviation from the number of Max Vacuum. Any deviation means lack of precise calibration of the apparatus vacuum. With following method you can calibrate the apparatus.

By pressing the Vac.Cl key calibration operations are initiated automatically and you just need to wait for 3-5 minutes to finish this operation. Within the time of calibration never disconnect the pump from the furnace and if the operation was stopped due to any reason, you should repeat the path again until you attain a complete and correct calibration.

Fast cooling

Sometimes, it is necessary for the firing operations to be done speedily and with low interval. In this situation, when the program is terminated you want the next program initiate and also the temp of apparatus is higher than initial temp (low temperature). In this case, two options of “Yes” and ”No” appear on the apparatus board.

In this position if you press the Enter key, the fast firing program will be performed as follows: the furnace door is opened and the vacuum pump initiates evacuating of air from the chamber. If there was not any need for fast firing,press the ”Clear” key which means no implementation.

POLARIS AT-300

Troubleshooting

Troubleshooting

Observed problem on the apparatus screen	Observed problem	Test and solution
Vacuum Fail	Vacuum amount does not reach to the determined level	The lower door and ring should be carefully examined and cleaned. The connections of pump to the furnace be tested. The pressure be tested separately and directly connected to main power.
Door Fail	The door does not move up or down or does not stop on the desired place	If the door doesn't stop in desired place the micro switches have problems. Test the micro switches separately, if they are intact we should check all connections to main board and location of micro switches, so that the main location is not lower or higher. Use setting knobs. In case of damage, replace the micro switches with a new one. In case the door does not move or has a noise, there is a barrier that it should be taken out, or the machine parts have some problems which should be removed and if the mechanical parts have problems they should be repaired.
Muffle Fail	The temperature does not rise	The element should be replaced the connecting tools to heating system such as SSR and connecting wires should be replaced.
Enter 0<P.No<299	The program doesn't change	The number of selective authorized programs in this apparatus is 300 progs from 0 to 299 your choice should be one of them.
Enter 200<T<1200 Enter 392<T<2192	The apparatus does not accept the given time that operator sets.	The given temp should be within 200 to 1200 cent. The chosen temp should be between 392 to 2192 Fahrenheit
Enter 0:10 < t < 99:59	The machine does not accept the time given	The chosen time should be between 10 sec to 99 min and 59 sec
Enter LowT<T<1200 Enter LowT<T<2192	The apparatus does not accept the firing temperature	Firing temp Should be within initial temp and 1200 degree. The firing temp should be within initial temp and 2192 Fahrenheit

Enter Due to HR	DOES NOT ACCEPT the given time	The given time should pass the interval between the initial temperature and the firing temperature with the speed lower than 120° per minute.
Enter 20<HR<120 Enter 68<HR<248	DOES NOT ACCEPT the temp rising	The temperature speed rate should be between 20 to 120 centigrade and 68 to 248 Fahrenheit
Enter 30<Vac<100	DOES NOT ACCEPT amount of Vac	Amount of vacuum should be within 30 to 100%
Enter LowT<T<Hi.T	DOES NOT ACCEPT the given temp	The temp for initiating vacuum should be between initial temp and firing temp
Enter EvacT<T<Hi.T	DOES NOT ACCEPT the given time	The initial temp should be within initial temp and firing temp.
Enter Evac T<T<Hi	Does not accept the given temp	The terminal temp should be between initial temp of vac and firing temp
Thermocouple Fail	Temp doesn't change	The apparatus thermocouple has problem. The connectivity service of thermocouple or its connections have problem.
Enter 200<T<800	DOES NOT ACCEPT the given temp	The initial temp should be between 200 to 800 centigrade. The initial temp should be between 392 to 1472 Fahrenheit.
Thermometer Fail	Temp of machine is not correct	A/D machine is out of order
Valve Fail	Vacuum does not calibrate	The electrical valves do not work because of pollution or they are out of order and they should be repaired and replaced.

Service & Maintenance

Cases expanding the apparatus lifetime

- Do not turn on and off the furnace repeatedly and frequently.

- It is recommended to use Night program after turning ON the furnace in the morning (in the cold phase) or after idle position for a long time, this is useful for preventing moisture penetration of air and environment on the furnace muffle and also increasing its lifetime. For activating press Night key and then Start key.

- It is recommended to use Dry program every two months in order to dry the muffle completely. (the "Dry" program has been explained completely in page 25)

- In case you haven't used the apparatus for several continuous days, you should dry the heating system completely by Dry program.

- The optimum temp for turning off the furnace is 100 °, also close the furnace door to prevent the moisture penetration in to the muffle.

- The firing tray has a height of 50 mm and is an additional thermal insulation. Surely, if its height becomes low or it is fractured, it leads to thermal leak of the door and chamber and consequently the apparatus will be damaged. Therefore, it should be replaced. In this case, please contact with the technical part of the company.

- Don't touch to the inner chamber of the elements when it is On or Hot.

- Don't put the containers of liquid on the apparatus.

- Don't put the containers of liquid on the apparatus. Don't clean the apparatus with detergents when it is On and working. For cleaning the apparatus, disconnect the back cable of the furnace and use the ordinary detergents. Don't keep the panel's surface wet for more than 1 minute.

 Individuals or technicians who are not trained to work with this apparatus are not authorized to use it. The company is not responsible for abuse of the apparatus. Be careful; after cleaning the apparatus; do not turn on the furnace until it becomes dry.

Important: In case of any technical problem, only contact with after sales service of Polaris company Please refrain from giving the device to other individuals; otherwise, the company is not responsible.



Calling the aftersales services Unit of Polaris Co.

Tel: [+49 \(0\) 21033373500](tel:+49(0)21033373500) Fax: [+49 \(0\) 21033373550](tel:+49(0)21033373550)

Web: www.polarisgmbh.com

Email: Service@polarisgmbh.com





www.polarisgmbh.com